

Seemax International School Sasni, Hathras

Class- XII
Subject- Physics (Assignment)

CHAPTER 2 Electric Potential and Capacitance

SECTION A CONCEPTUAL AND APPLICATION TYPE QUESTIONS

- 1 Can the electric potential at a point be zero , while the electric field is non zero? Justify 1
- 2 Can the electric field at a point be zero , while the electric potential is non zero? Justify. 1
- 3 Why work done in taking a charge between any two points of an equipotential surface? 1
- 4 Show that electric field is always perpendicular to an equipotential surface. 1(2001)
- 5 The capacitance of a charged capacitor is C and the energy stored in it is U . Write the expression for Q in terms of C and U. 1
- 6 (a) An infinitely long positively charged straight wire has a linear charge density $\lambda \text{ Cm}^{-1}$. An electron is revolving around the wire as its centre with a constant velocity in a circular plane perpendicular to the wire. Deduce the expression for its kinetic energy.
(b) Plot a graph of the kinetic energy as a function of charge density λ . 3(2013)
- 7 Derive the expression for the electric potential at any point along the axial line of an electric dipole. 2(2008)
- 8 A parallel plate capacitor is charged by a battery. After some time the battery is disconnected and a dielectric slab of dielectric constant K is inserted between the plates. How would (i) the capacitance, (ii) the electric field between the plates and (iii) the energy stored in the capacitor, be affected? Justify your answer. 3(2009)
- 9 A charge +Q is placed on a large spherical conducting shell of radius R. Another small conducting sphere of radius r carrying charge 'q' is introduced inside the large shell and is placed at its centre. Find the potential difference between two points, one lying on the sphere and the other on the shell.
(b) How would the charge between the two flow if they are connected by a conducting wire?
Name the device which works on this fact. 3(2009)
- 10 Depict the equipotential surfaces for a system of two identical positive point charges placed distance 'd' apart. 3(2010)
(b) Deduce the expression for the potential energy of a system of two point charges q_1

and q_2 brought from infinity to the points \vec{r}_1 and \vec{r}_2 respectively in the presence of external electric field \vec{E}

- 11 The given graph shows that variation of charge q versus potential difference V for two capacitors A and B. The two capacitors have same plate separation but the plate area of B is double than that of A. Which of the lines in the graph correspond to A and B? Justify. 2

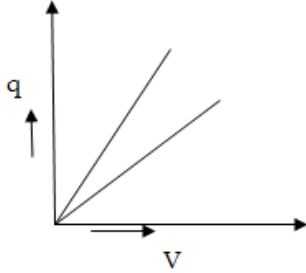

- 12 If the plates of a charged capacitor be suddenly connected to each other by a copper wire, what will happen? 1(repeated)
- 13 If a dielectric slab between the parallel plates of a capacitor is replaced by a metal plate of same thickness $t < d$ where d is the separation between the plates of the capacitor, how does its capacitance change? 2
- 14 What is the direction of electric field line at a point with respect to equipotential surface? Give reason. 1
- 15 Draw an equipotential surface for a system, consisting of two charges $Q, -Q$ separated by a distance ' r ' in air.
- 16 Sketch a graph to show the dependence of a charge Q stored in a capacitor on the potential difference V applied. From the graph drawn how will you calculate the capacitance C of the capacitor and the energy U stored in the capacitor 2
- 17 If a dielectric slab of dielectric constant K is introduced between the plates of a parallel plate capacitor completely, how does the energy density of the capacitor change? 1
- 18 The following table shows the dimensions and medium between the plates of three capacitors P, Q and R. Rank them in increasing order of their capacitances. 2

s.no	Capacitor	Area of plates	Separation between the plates	Medium between the plates
1	P	A	D	Medium of $\epsilon_r=4$
2	Q	2A	D/2	air
3	R	2A	D	Medium of $\epsilon_r=2$

- 19 A point charge Q is placed at point O as shown in the figure. Is the potential difference 1(2015)

$V_A - V_B$ positive, negative, or zero, if Q is (i) positive (ii) negative?

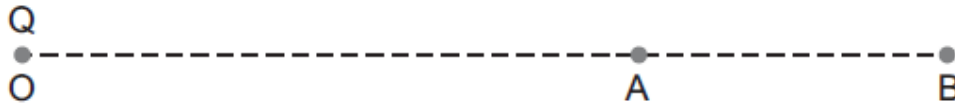

- 20 The capacitance of a charged capacitor is C and the energy stored in the capacitor is U . Write the expression for the charge Q in terms of C and U . 1
- 21 If a dielectric slab of dielectric constant K is introduced between the plates of a parallel plate capacitor completely, how does the energy density of the capacitor change? 1
- 22 Plot a graph between the variation of energy U stored in a capacitor and the capacitance C when the charge stored is Q is constant. 1
- 23 An infinitely long positively charged straight wire has a linear charge density $\lambda \text{ Cm}^{-1}$. An electron is revolving around the wire as its centre with a constant velocity in a circular plane perpendicular to the wire.
- (a) Deduce the expression for its kinetic energy.
- (b) Plot a graph of the kinetic energy as a function of charge density λ

SECTION B NUMERICAL PROBLEMS

- 1 Two charges $-q$ and $+q$ are located at points $A(0, 0, -a)$ and $B(0, 0, +a)$ respectively. How much work is done in moving a test charge from point $P(7, 0, 0)$ to $Q(-3, 0, 0)$? 1(2008)
- 2 The equivalent capacitance of the combination between A and B in the given figure is $4 \mu\text{F}$. (i) Calculate capacitance of the capacitor C. (ii) Calculate charge on each capacitor if a 12 V battery is connected across terminals A and B. (iii) What will be the potential drop across each capacitor? 3(2008)

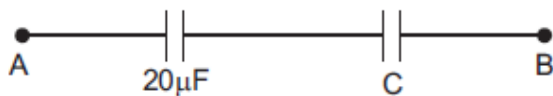

- 3 Three identical capacitors C_1 , C_2 and C_3 of capacitance $6 \mu\text{F}$ each are connected to a 12 V battery as shown. 3(2009)

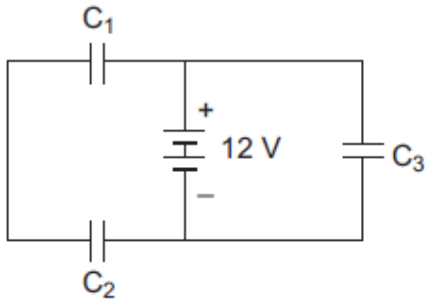

Find:

- (i) charge on each capacitor
- (ii) equivalent capacitance of the network
- (iii) energy stored in the network of capacitors

- 4 A $500 \mu\text{C}$ charge is at the centre of a square of side 10 cm. Find the work done in moving a charge of $10 \mu\text{C}$ between two diagonally opposite points on the square. 1(2008)
- 5 Calculate the work done to dissociate the system of three charges placed on the vertices of a triangle as shown. Here $q = 1.6 \times 10^{-10} \text{ C}$. 3(2008)

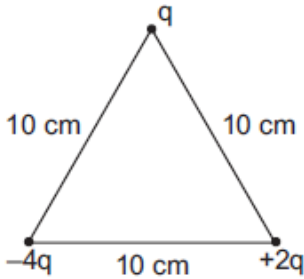

- 6 Obtain the equivalent capacitance of the network given below. For a supply of 300 V, determine the charge and voltage across C_4 . 3(2008)

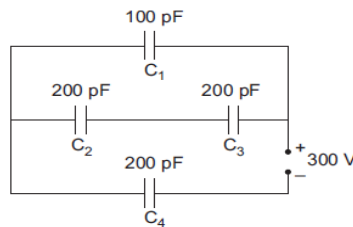

- 7 Two parallel plate capacitors X and Y, have the same area of plates and same separation between them. X has air between the plates while Y contains a dielectric medium of $K = 4$. 3(2008)
- (i) Calculate capacitance of each capacitor if equivalent capacitance of the combination is $4 \mu\text{F}$.

(ii) Calculate the potential difference between the plates of X and Y.

(iii) What is the ratio of electrostatic energy stored in X and Y?

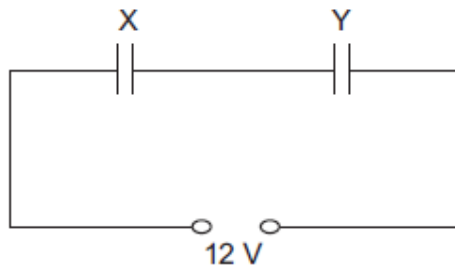

8 A 800 pF capacitor is charged by a 100 V battery. After some time the battery is disconnected. The capacitor is then connected to another 800 pF capacitor. What is the electrostatic energy stored? 2(2009)

9 Calculate the electric potential at a point P, located at the centre of the square of point charges shown in the figure. 2

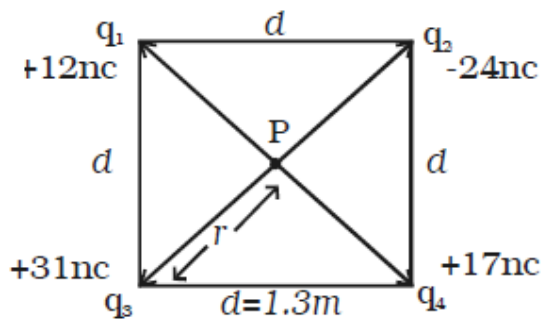

10 Calculate the capacitance of the arrangement of two parallel plates of area A separated by a distance of d between them. K_1 , K_2 , and K_3 are the dielectric constants of the three materials in between the plates as in the figure. 2

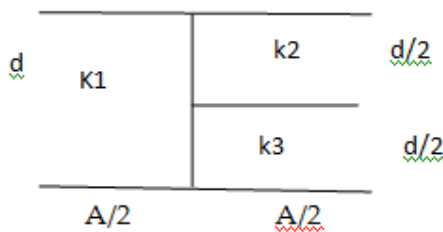

11 You are given an air filled parallel plate capacitor C_1 . The space between its plates is now filled with slabs of dielectric constants K_1 and K_2 as shown in C_2 . Find the capacitances of the capacitor C_2 if area of the plates is A and distance between the plates is d. 2(2011)

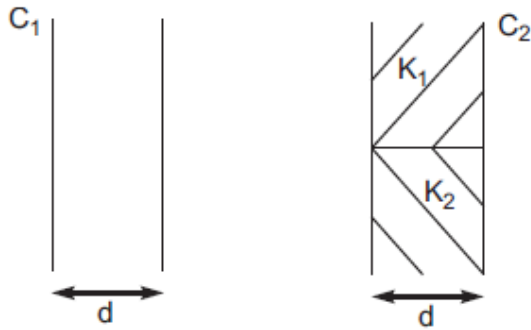

- 12 Two identical parallel plate (air) capacitors \$C_1\$ and \$C_2\$ have capacitances \$C\$ each. The between their plates is now filled with dielectrics as shown. If the two capacitors still have equal capacitance, obtain the relation between dielectric constants \$K\$, \$K_1\$ and \$K_2\$. (2011) 2

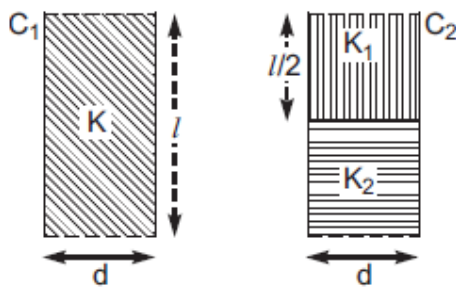

- 13 An electric dipole of length 1 cm, which placed with its axis making an angle of \$60^\circ\$ with uniform electric field, experiences a torque of \$6\sqrt{3}\$ Nm. Calculate the potential energy of the dipole if it has charge \$\pm 2\$ nC. (2014) 2
- 14 A capacitor of unknown capacitance is connected across a battery of \$V\$ volts. The charge stored in it is \$360 \mu\text{C}\$. When potential across the capacitor is reduced by 120 V, the charge stored in it becomes \$120 \mu\text{C}\$. (2013) 3

Calculate:

- (i) The potential \$V\$ and the unknown capacitance \$C\$.
- (ii) What will be the charge stored in the capacitor, if the voltage applied had increased by 120 V?
- 15 Figure shows two identical capacitors \$C_1\$ and \$C_2\$ each of 1.5 mF capacitance, connected to a battery of 2 V. Initially switch 'S' is closed. After sometimes 'S' is left open and dielectric slabs of dielectric constant \$K = 2\$ are inserted to fill completely the space between the plates of the two capacitors. How will the (i) charge and (ii) potential difference between the plates of the capacitors be affected after the slabs are inserted?

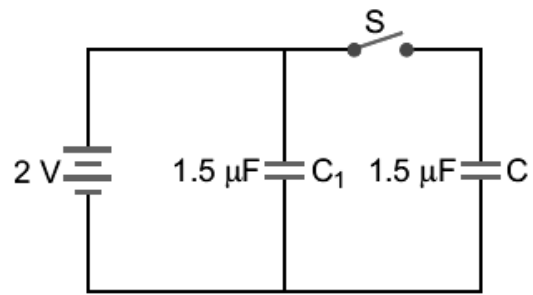

- 16 A network of four capacitors each of $15 \mu\text{F}$ capacitance is connected to a 500 V supply 3 (2010) as shown in the figure. Determine (a) equivalent capacitance of the network and (b) charge on each capacitor.

